

Illustration Auswurf-träger fangkorb

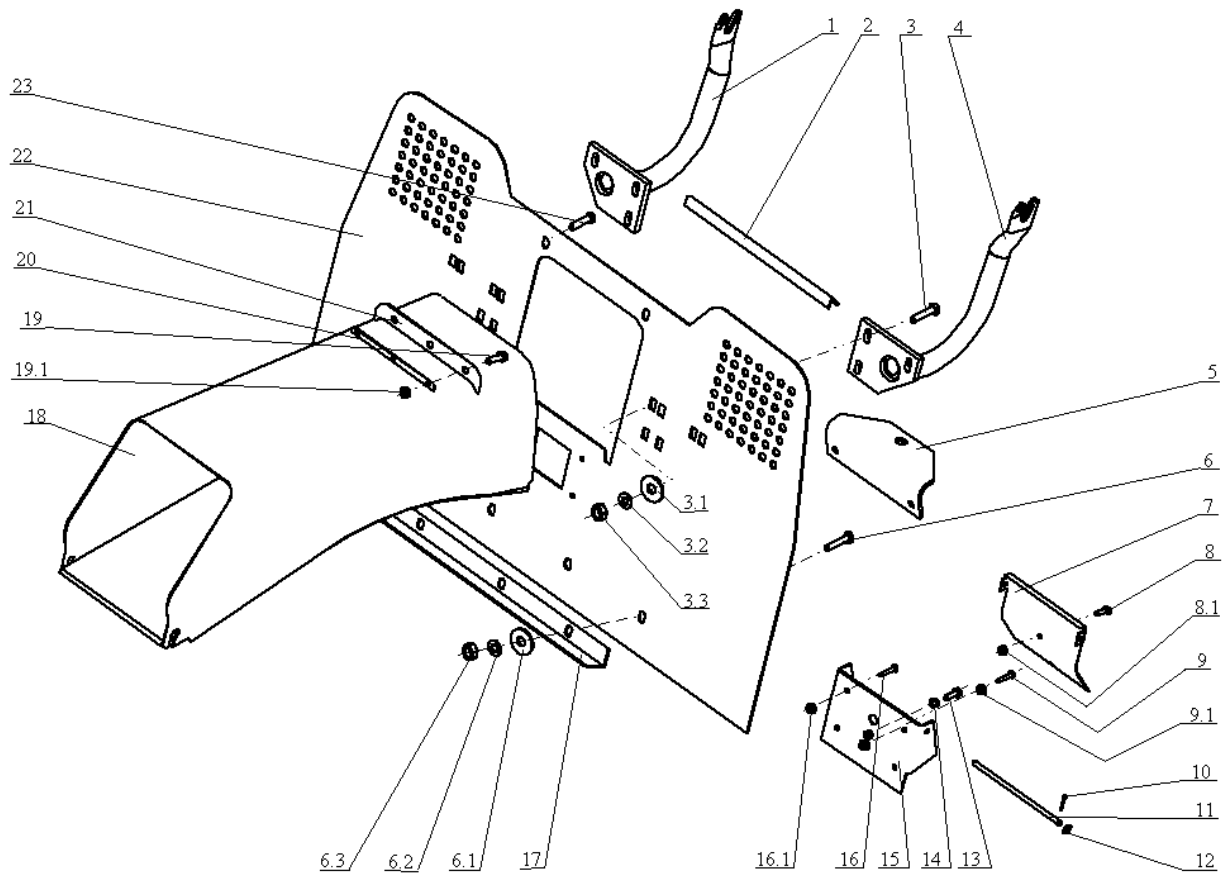

Illustration Auswurf-träger fangkorb

Bild Nr.	St.- Zahl	Teile Nr.	Beschreibung
1	1	SG532974432173	Halter
2	1	SG532096362013	Dichtung
3	6	SG947309578011	Sechskantschraube
3.1	6	SG947311210503	Scheibe
3.2	6	SG947311214502	Scheibe
3.3	6	SG947311120502	Mutter
4	1	SG532974432163	Halter
5	1	SG532113402453	Halter
6	4	SG947309578011	Sechskantschraube
6.1	4	SG947311210503	Scheibe
6.2	4	SG947311214502	Scheibe
6.3	4	SG947311120502	Mutter
7	1	SG532085352033	Schlüssel
8	1	SG947309019520	Schraube
8.1	2	SG947311120530	Sechskantmutter
9	1	SG947309203559	Schraube
9.1	1	SG947311120513	Sechskantmutter
10	2	SG947311338501	Splint
11	1	SG532014102103	Stift
12	2	SG947311210502	Scheibe
13	1	SG947309231529	Schraube
14	1	SG947315231195	Feder
15	1	SG532913462413	Halter
16	4	SG947309203539	Schraube
16.1	4	SG947311129515	Sichermutter
17	1	SG532113403233	Halter
18	1	SG532974472253	Auswurfschacht
19	3	SG947309231502	Schraube
19.1	3	SG947311120505	Mutter
20	1	SG532115308573	Scheibe
21	1	SG532113322813	Halter
22	1	SG532974422193	Deflector
23	2	SG947309503005	Schraube

Illustration Eletrischeile

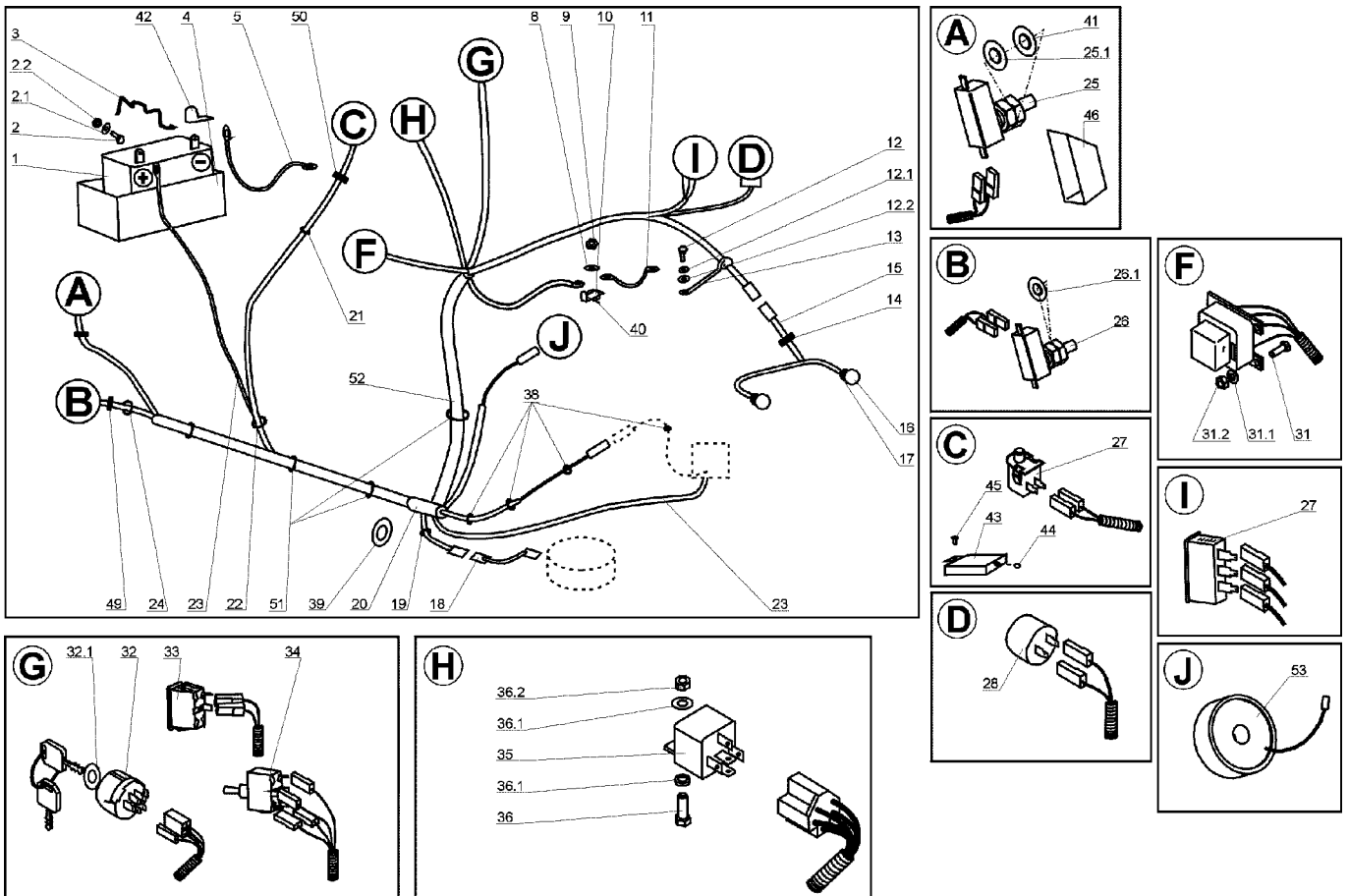

Illustration Elektrische Teile

Bild Nr.	St.- Zahl	Teile Nr.	Beschreibung
1	1	SG947346211006	Batterie
2	2	SG947309203502	Sechskantschraube
2.1	2	SG947311210502	Scheibe
2.2	2	SG947311129513	Sichermutter
3	1	SG947532880041	Klemme
4	1	SG947232130001	Batteriekasten
5	1	SG947341271021	Kabel
8	1	SG947311210501	Scheibe
9	1	SG947311129515	Sichermutter
10	1	SG532113402583	Halter
11	1	SG947341271006	Anzeiger
12	1	SG947309203504	Schraube
12.1	1	SG947311214502	Scheibe
12.2	1	SG947311210503	Scheibe
13	1	SG947532150125	Halter
14	1	SG947532150211	Klemme
15	1	SG947341271036	Kabel
16	2	SG947347224006	Glühlampe
17	2	SG947443953001	Klemme
18	1	SG947341271052	Diode
19	1	SG947273121029	Buchse
20	1	SG947341271101	Kabel
21	1	SG947273121036	Buchse
22	1	SG947273121036	Buchse
23	1	SG947341271049	Anzeiger
24	2	SG947321841071	Klammer
25	1	SG947358113026	Schalter
25.1	1	SG947311210505	Scheibe
26	1	SG947358113026	Schalter
26.1	2	SG947311210505	Scheibe
27	1	SG947000532079	Sitz
28	1	SG947443312021	Warnlicht
31	2	SG947309203548	Schraube
31.1	4	SG947311210501	Scheibe
31.2	2	SG947311129515	Sichermutter
32	1	SG947443861005	Sperre
32.1	1	SG532092207513	Scheibe
33	2	SG947345329013	Schalter
34	1	SG947000532039	Schalter
35	1	SG947443811004	Relais
36	1	SG947309203548	Schraube
36.1	1	SG947311210501	Scheibe
36.2	1	SG947311129515	Sichermutter
38	4	SG947321841071	Klammer
39	1	SG947532150055	Deckel
40	1	SG947532150207	Ring

Illustration Eletrischeile

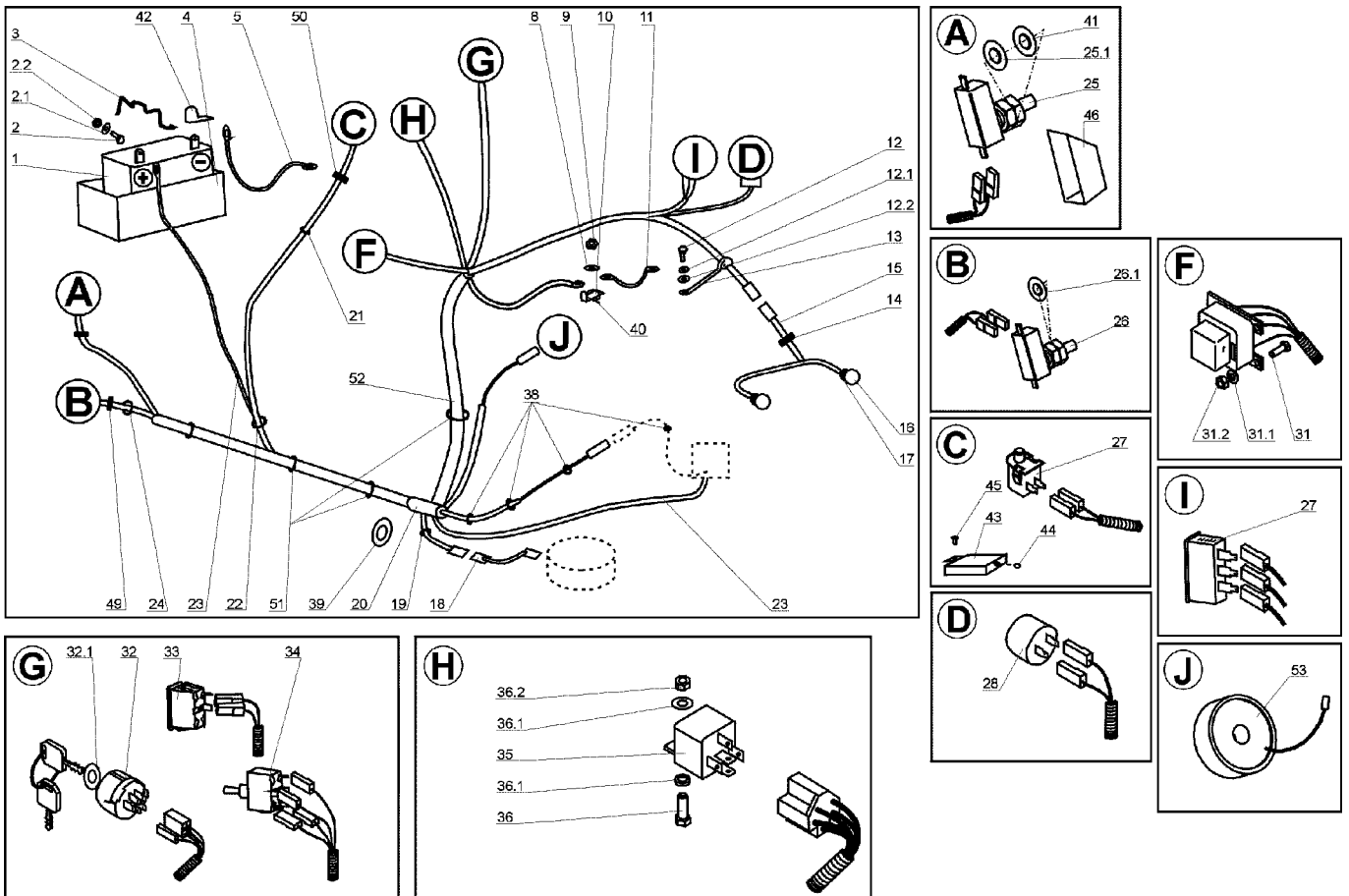

Illustration Eletrischeteile

Bild Nr.	St.- Zahl	Teile Nr.	Beschreibung
41	1	SG947311219498	Scheibe
42	2	SG947273125006	Klemme
43	1	SG532085427153	Sitz
44	1	SG947273121035	Durchföhrung
45	1	SG947311691001	Niete
46	1	SG532085427173	Deckel
49	2	SG947532150211	Klemme
50	1	SG947532150211	Klemme
51	4	SG947532150207	Ring
52	1	SG947286134002	Rohr
53	1	SG947358352009	Tempogerat

Illustration Getriebe

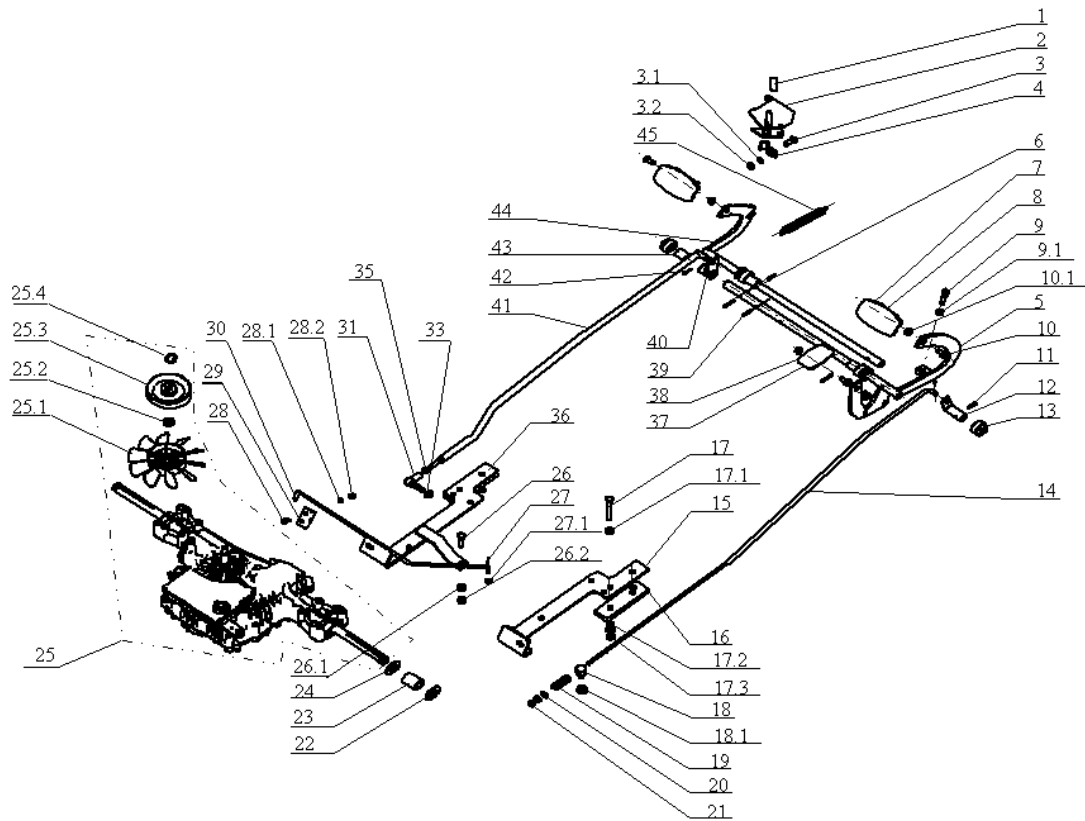

Illustration Getriebe

Bild Nr.	St.- Zahl	Teile Nr.	Beschreibung
1	1	SG947532150209	Stecker
2	1	SG532980712323	Hebel
3	1	SG947309503518	Schraube
3.1	1	SG947311214502	Scheibe
3.2	1	SG947311120502	Mutter
4	1	SG532080412363	Halter
5	1	SG532980442213	Hebel
6	3	SG947311338517	Splint
7	1	SG947273151011	Fusshebel
8	2	SG532980512573	Fusshebel
9	2	SG947309203530	Schraube
9.1	2	SG947311120502	Mutter
10	3	SG947309203504	Schraube
10.1	3	SG947311129501	Sichermutter
11	2	SG947315238050	Feder
12	1	SG532980365183	Kupplungsblock
13	4	SG947722643023	Buchse
14	1	SG532080412873	Anschluss
15	1	SG532113403863	Halter
16	2	SG532092303943	Scheibe
17	4	SG947309501571	Schraube
17.1	8	SG947311210503	Scheibe
17.2	4	SG947311214502	Scheibe
17.3	4	SG947311120502	Mutter
18	1	SG947532150507	Schraube
18.1	1	SG947311129502	Mutter
19	1	SG947315231240	Feder
20	1	SG947311212517	Scheibe
21	2	SG947311120520	Mutter
22	10	SG532092208153	Scheibe
23	2	SG947532150542	Buchse
24	2	SG532092207393	Scheibe
25	1	SG947532991052	Getriebe
25.1	1	SG947532150376	Lufferrad
25.2	1	SG000000070141	Scheibe
25.3	1	SG000000070137	Scheibe
25.4	1	SG000000070134	Scheibe
26	1	SG947309203506	Schraube
26.1	1	SG947311210503	Scheibe
26.2	1	SG947311129501	Sichermutter
27	1	SG947311338513	Splint
27.1	1	SG947311210502	Scheibe
28	2	SG947309203539	Schraube
28.1	2	SG947311214507	Scheibe
28.2	2	SG947311120506	Mutter
29	1	SG532113403913	Halter

Illustration Getriebe

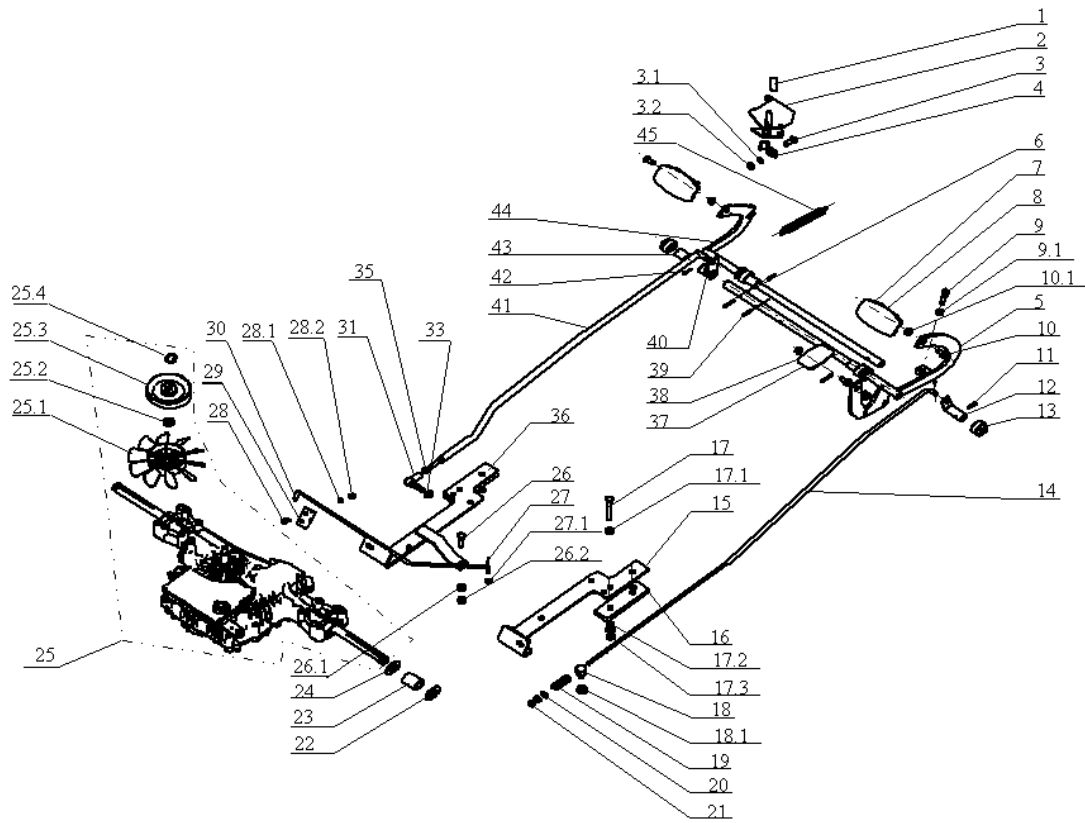

Illustration Getriebe

Bild Nr.	St.- Zahl	Teile Nr.	Beschreibung
30	1	SG532080452513	Bride
31	1	SG947442073023	Dichtung
33	1	SG947311129520	Mutter
35	1	SG947311150503	Mutter
36	1	SG532913368443	Halter
37	1	SG532980512583	Fusshebel
38	2	SG947273151001	Pedalgummi
39	1	SG947315238037	Splint
40	1	SG532980364823	Arm
41	1	SG532980422103	Bride
42	1	SG947311338501	Splint
43	3	SG947532150541	Buchse
44	1	SG532980442243	Bremsepedal
45	1	SG947315231160	Feder

Illustration Grasfangkorb

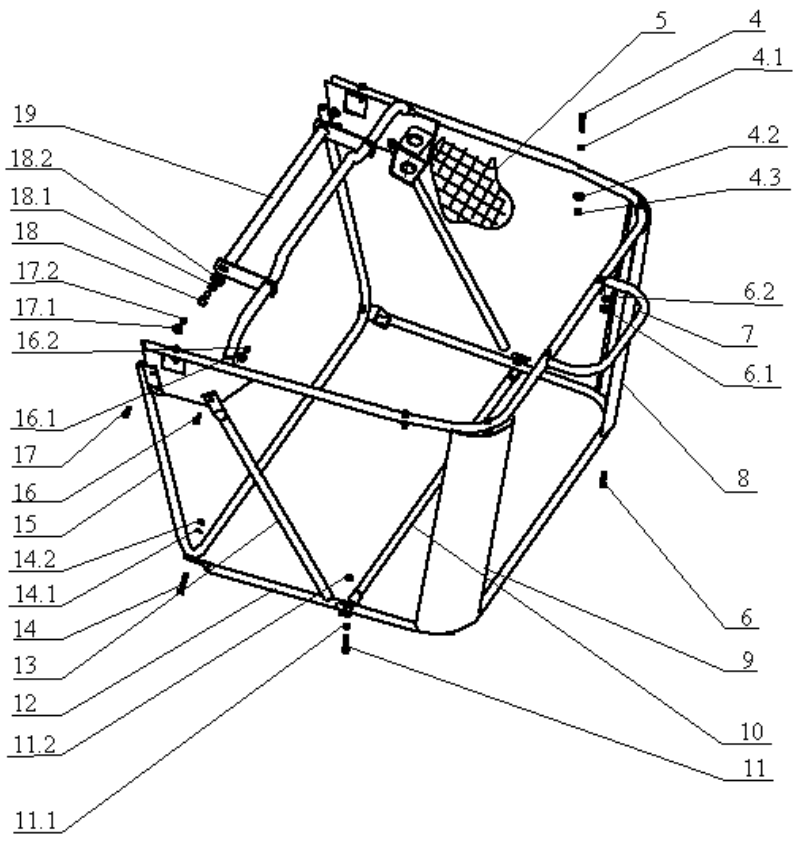
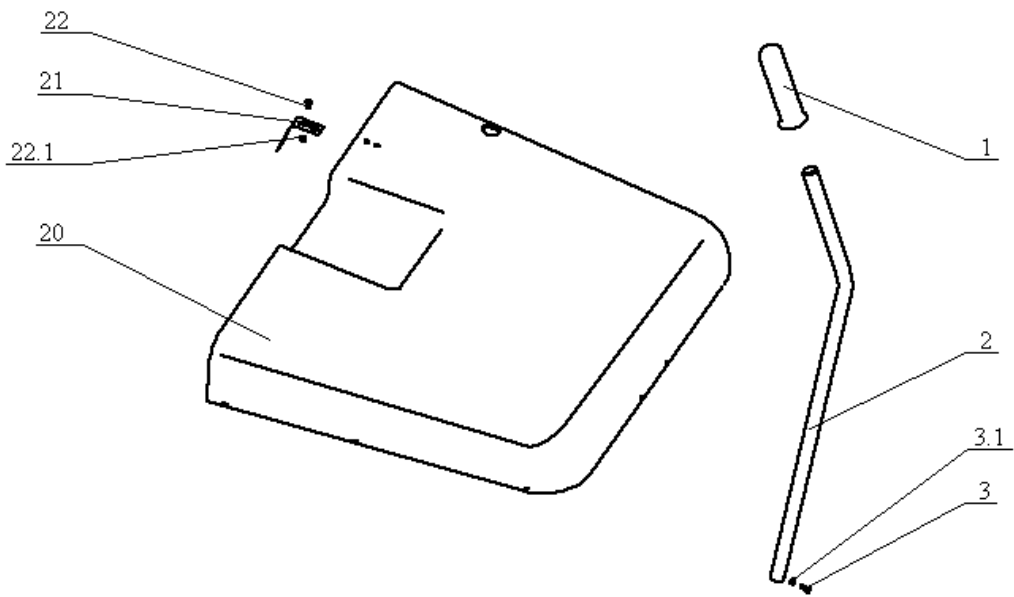

Illustration Grasfangkorb

Bild Nr.	St.- Zahl	Teile Nr.	Beschreibung
1	1	SG947532150007	Handgriff
2	1	SG532074202013	Hebel
3	1	SG947309203548	Schraube
3.1	1	SG947311129515	Sichermutter
4	6	SG947309203555	Sechskantschraube
4.1	6	SG947311210501	Scheibe
4.2	6	SG947311212514	Scheibe
4.3	6	SG947311129515	Sichermutter
5	1	SG947532150135	Aschluss
6	4	SG947309203557	Sechskantschraube
6.1	4	SG947311210501	Scheibe
6.2	4	SG947311129515	Sichermutter
7	1	SG532974472293	Rahmen
8	1	SG532074422263	Halter
9	1	SG532074422273	Halter
10	1	SG532074262013	Rohr
11	2	SG947309203556	Sechskantschraube
11.1	2	SG947311210501	Scheibe
11.2	2	SG947311129515	Sichermutter
12	1	SG532974462013	Rahmen
13	2	SG532074262023	Rahmen
14	2	SG947309203555	Sechskantschraube
14.1	2	SG947311210501	Scheibe
14.2	2	SG947311129515	Sichermutter
15	1	SG532974442013	Rahmen
16	2	SG947309203539	Schraube
16.1	2	SG947311210501	Scheibe
16.2	2	SG947311129515	Sichermutter
17	4	SG947309019514	Schraube
17.1	4	SG947311212514	Scheibe
17.2	4	SG947311129515	Sichermutter
18	2	SG947309203504	Schraube
18.1	2	SG947311214502	Scheibe
18.2	2	SG947311212508	Scheibe
19	1	SG532980202103	Handgriff
20	1	SG947532150193	Deckel
21	1	SG532097402153	Feder
22	2	SG947309251313	Schraube
22.1	2	SG947311129515	Sichermutter

Illustration Hinterachse

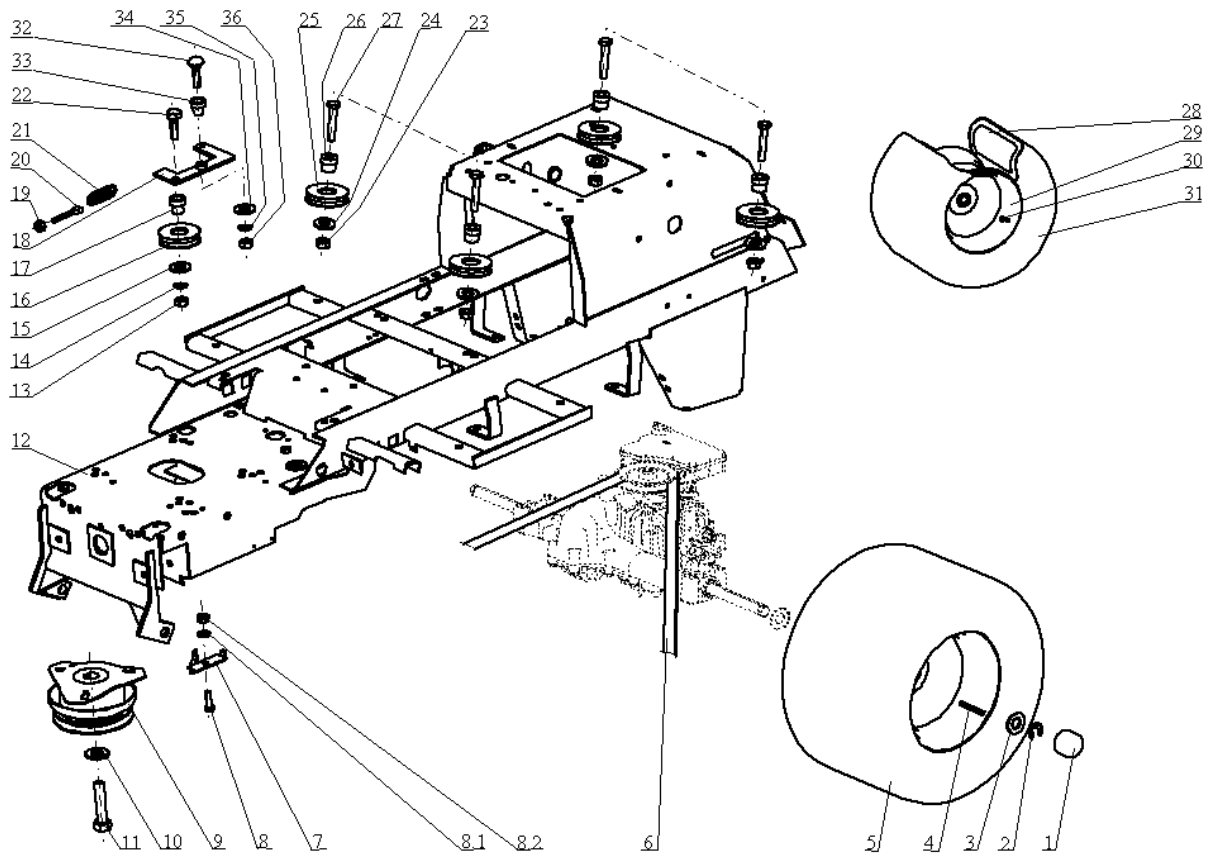

Illustration Hinterachse

Bild Nr.	St.- Zahl	Teile Nr.	Beschreibung
1	2	SG947532150208	Deckel
2	2	SG947311732008	Kobelring
3	2	SG532092207393	Scheibe
4	2	SG532092312163	Feder
5	2	SG947000532094	Rad
6	1	SG947272731199	Riemen
7	1	SG532936362163	Führung
8	1	SG947309203504	Schraube
8.1	1	SG947311214502	Scheibe
8.2	1	SG947311120502	Mutter
9	1	SG947000532010	Kupplung
9	1	SG947339242006	Kupplung
10	1	SG947311214012	Scheibe
11	1	SG947309579509	Schraube
12	1	SG532912962633	Rahmen
13	1	SG947311120503	Sechskantmutter
14	1	SG947311214503	Scheibe
15	1	SG947311210504	Scheibe
16	1	SG947000532003	Scheibe
17	1	SG947532150544	Buchse
18	1	SG532913322763	Halter
19	1	SG947311129513	Sichermutter
20	1	SG947309578523	Schraube
21	1	SG947315231111	Feder
22	1	SG947309203528	Schraube
23	4	SG947311129502	Mutter
24	4	SG947311210504	Scheibe
25	4	SG947000532006	Scheibe
26	4	SG532094214183	Buchse
27	4	SG947309201512	Sechskantschraube
28	2	SG947000532133	Reifenschlauch
29	2	SG947000532134	Rad
30	2	SG947000532135	Ventil
31	2	SG947000532132	Reifen
32	1	SG947309203528	Schraube
33	1	SG947532150545	Buchse
34	1	SG947311210504	Scheibe
35	1	SG947311214503	Scheibe
36	1	SG947311120503	Sechskantmutter

Illustration Kapotte (1/2)

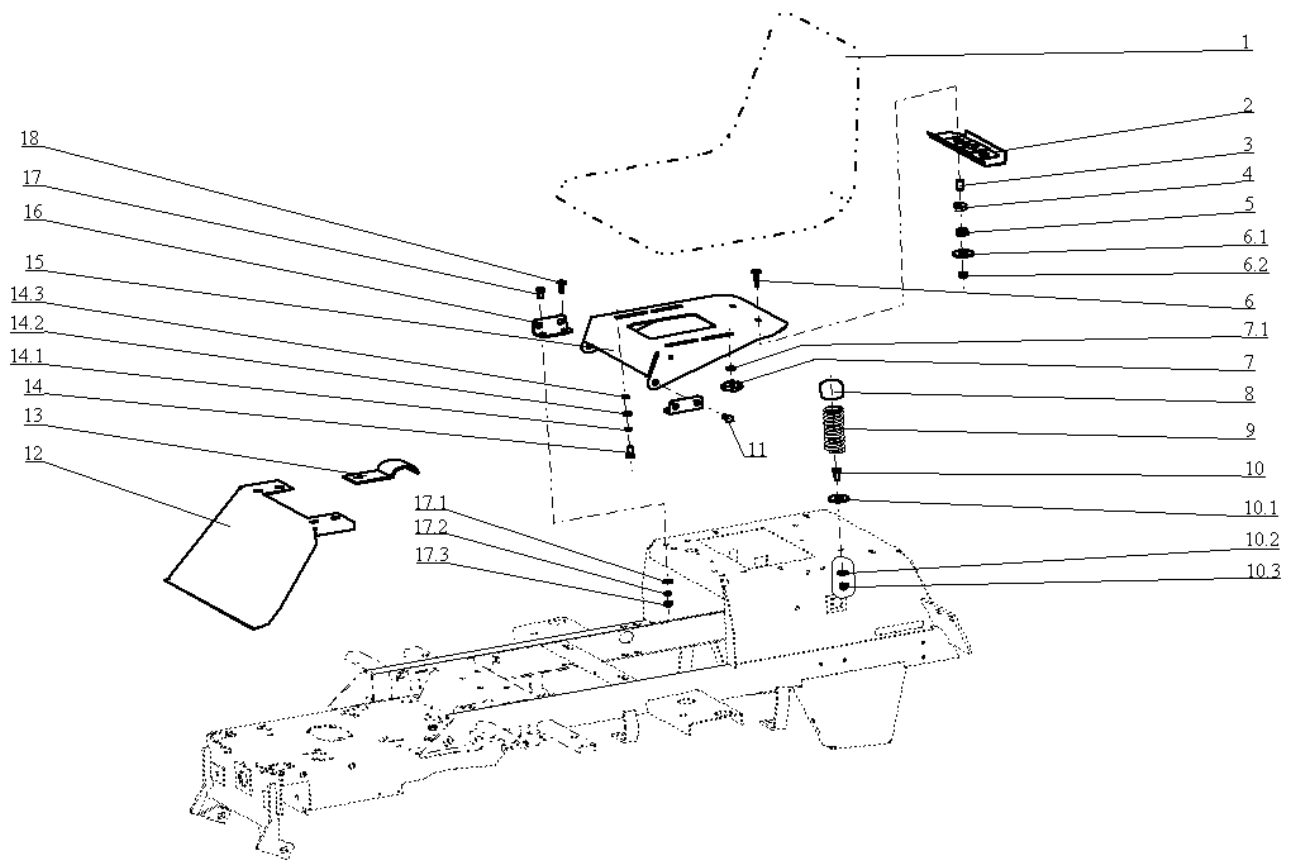

Illustration Kapotte (1/2)

Bild Nr.	St.- Zahl	Teile Nr.	Beschreibung
1	1	SG947532150212	Sitz
2	1	SG532983362153	Bride
3	2	SG947532150442	Distanzstuck
4	2	SG947315231194	Feder
5	2	SG947722643019	Buchse
6	2	SG947309019519	Schraube
6.1	2	SG947311212520	Scheibe
6.2	2	SG947311129513	Sichermutter
7	2	SG947532150213	Mutter
7.1	2	SG947311213503	Scheibe
8	2	SG947532150208	Deckel
9	2	SG947315231124	Feder
10	2	SG947309203504	Schraube
10.1	2	SG947311212517	Scheibe
10.2	2	SG947311210503	Scheibe
10.3	2	SG947311129501	Sichermutter
11	2	SG947309599012	Schraube
12	1	SG532018322413	Deckel
13	1	SG532113413453	Ring
14	2	SG947309203504	Schraube
14.1	2	SG947311214502	Scheibe
14.2	2	SG947311210503	Scheibe
14.3	2	SG947311219002	Scheibe
15	1	SG532018472433	Sitz
16	2	SG532113402403	Halter
17	3	SG947309203503	Schraube
17.1	6	SG947311210503	Scheibe
17.2	6	SG947311214502	Scheibe
17.3	6	SG947311120502	Mutter
18	2	SG947309203504	Schraube

Illustration Kapotte (2/2)

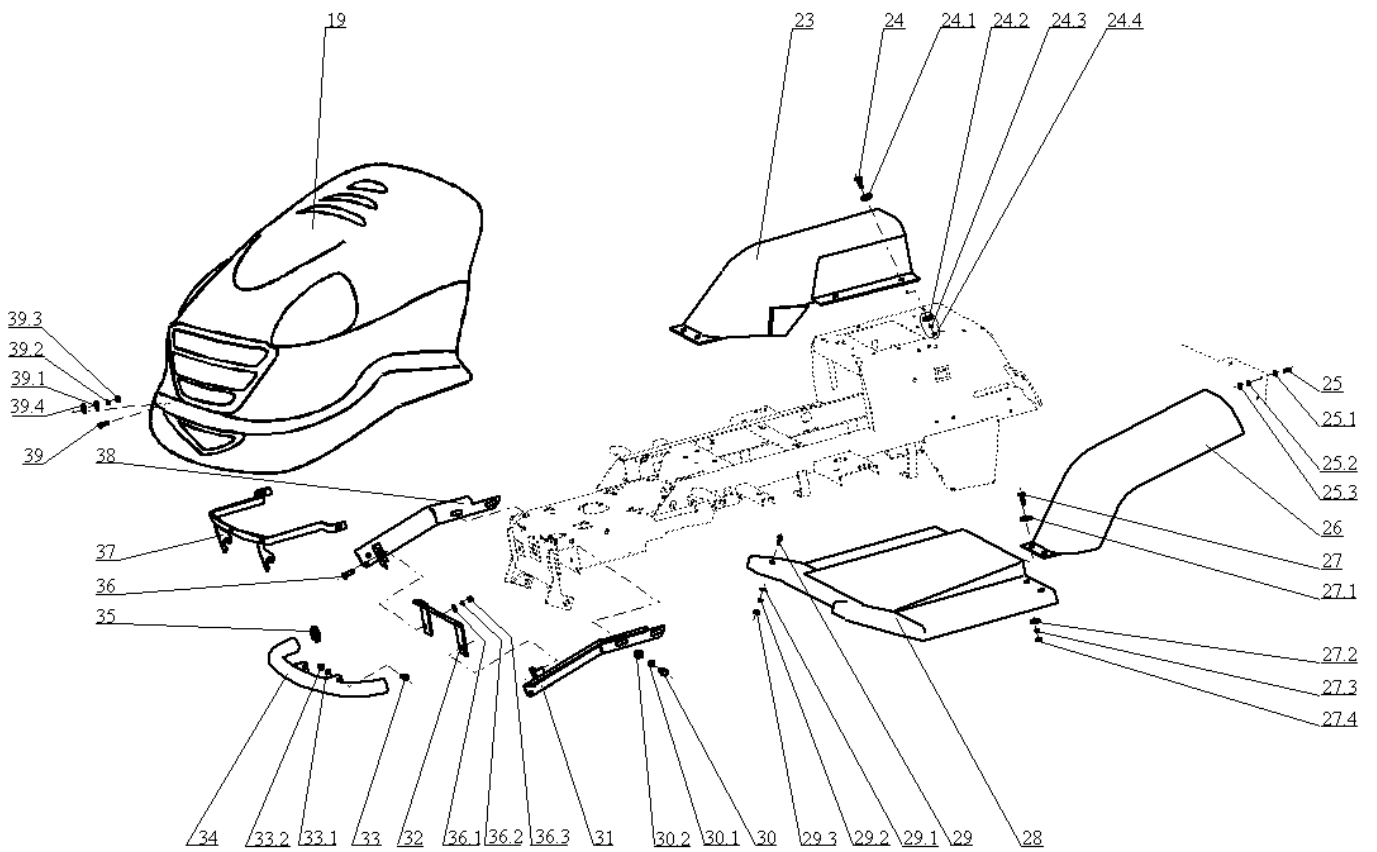

Illustration Kapotte (2/2)

Bild Nr.	St.- Zahl	Teile Nr.	Beschreibung
19	1	SG947532150611	Haube
23	1	SG947532150609	Kotflügel
24	4	SG947309578502	Schraube
24.1	4	SG947311219501	Scheibe
24.2	4	SG947311212514	Scheibe
24.3	4	SG947311214507	Scheibe
24.4	4	SG947311120506	Mutter
25	6	SG947309203518	Sechskantschraube
25.1	6	SG947311210506	Scheibe
25.2	6	SG947311212518	Scheibe
26	1	SG947532150610	Kotflügel
27	4	SG947309578502	Schraube
27.1	4	SG947311219501	Scheibe
27.2	4	SG947311212514	Scheibe
27.3	4	SG947311214507	Scheibe
27.4	4	SG947311120506	Mutter
28	1	SG532018473563	Schraube
29	6	SG947309019501	Schraube
29.1	6	SG947311210503	Scheibe
29.2	6	SG947311214502	Scheibe
29.3	6	SG947311120502	Mutter
30	4	SG947309203507	Schraube
30.1	4	SG947311214503	Scheibe
30.2	4	SG947311210504	Scheibe
31	1	SG532913368453	Bride
32	1	SG532913402953	Halter
33	4	SG947309203504	Schraube
33.1	4	SG947311214502	Scheibe
33.2	4	SG947311120502	Mutter
34	1	SG532918452063	Schutz
35	2	SG947321841068	Flansch
36	4	SG947309203517	Sechskantschraube
36.1	4	SG947311210503	Scheibe
36.2	4	SG947311214502	Scheibe
36.3	4	SG947311120502	Mutter
37	1	SG532918462113	Halter
38	1	SG532913368273	Bride
39	4	SG947309019521	Schraube
39.1	4	SG947311212511	Scheibe
39.2	4	SG947311214507	Scheibe
39.3	4	SG947311120506	Mutter
39.4	4	SG532096203923	Scheibe

Illustration Kapottepanel

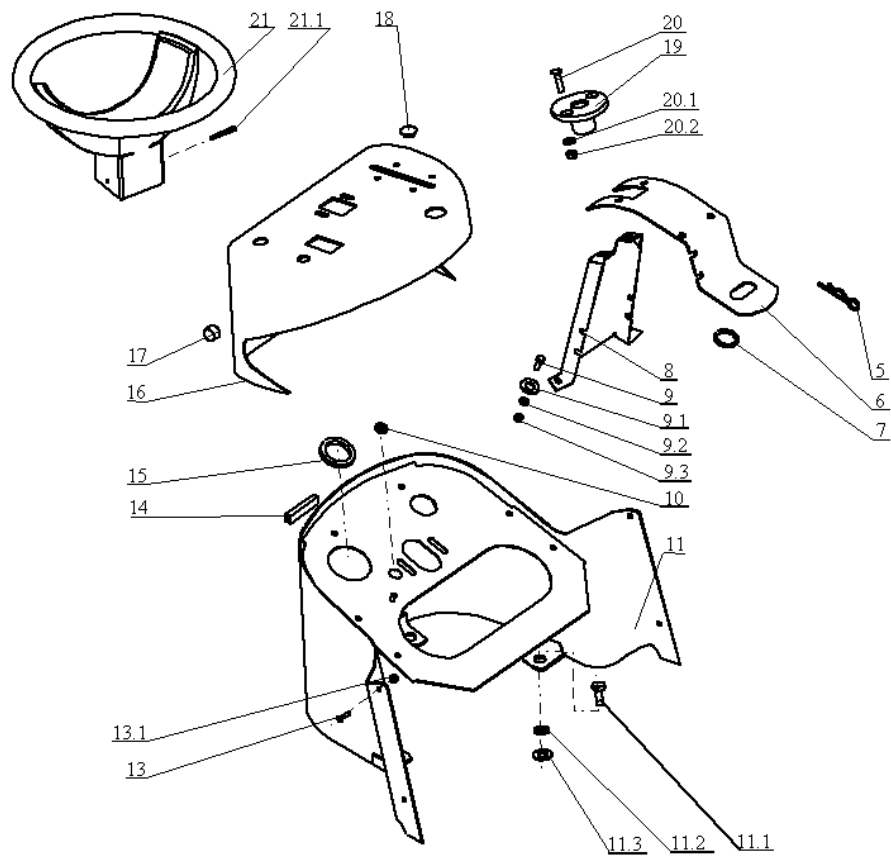

Illustration Kapottepanel

Bild Nr.	St.- Zahl	Teile Nr.	Beschreibung
5	1	SG947315238005	Ring
6	1	SG532013424353	Halter
7	1	SG947273121027	Buchse
8	1	SG532013424373	Bride
9	6	SG947309203539	Schraube
9.1	4	SG947311212514	Scheibe
9.2	2	SG947311210501	Scheibe
9.3	6	SG947311129515	Sichermutter
10	1	SG947273121036	Buchse
11	1	SG532980472093	Welle
11.1	4	SG947309203517	Sechskantschraube
11.2	4	SG947311214502	Scheibe
11.3	4	SG947311212517	Scheibe
13	2	SG947309251511	Schraube
13.1	2	SG947311129514	Mutter
14	1	SG532096342153	Dichtung
15	1	SG532096342053	Kabel
16	1	SG947532150612	Blechtafel
17	4	SG947532150238	Buchse
18	1	SG947321841082	Flansch
19	1	SG947321841059	Buchse
20	2	SG947309578503	Schraube
20.1	2	SG947311210502	Scheibe
20.2	2	SG947311129513	Sichermutter
21	1	SG947443821006	Lenkrad
21.1	1	SG947315238031	Splint

Illustration Lenkgetriebe

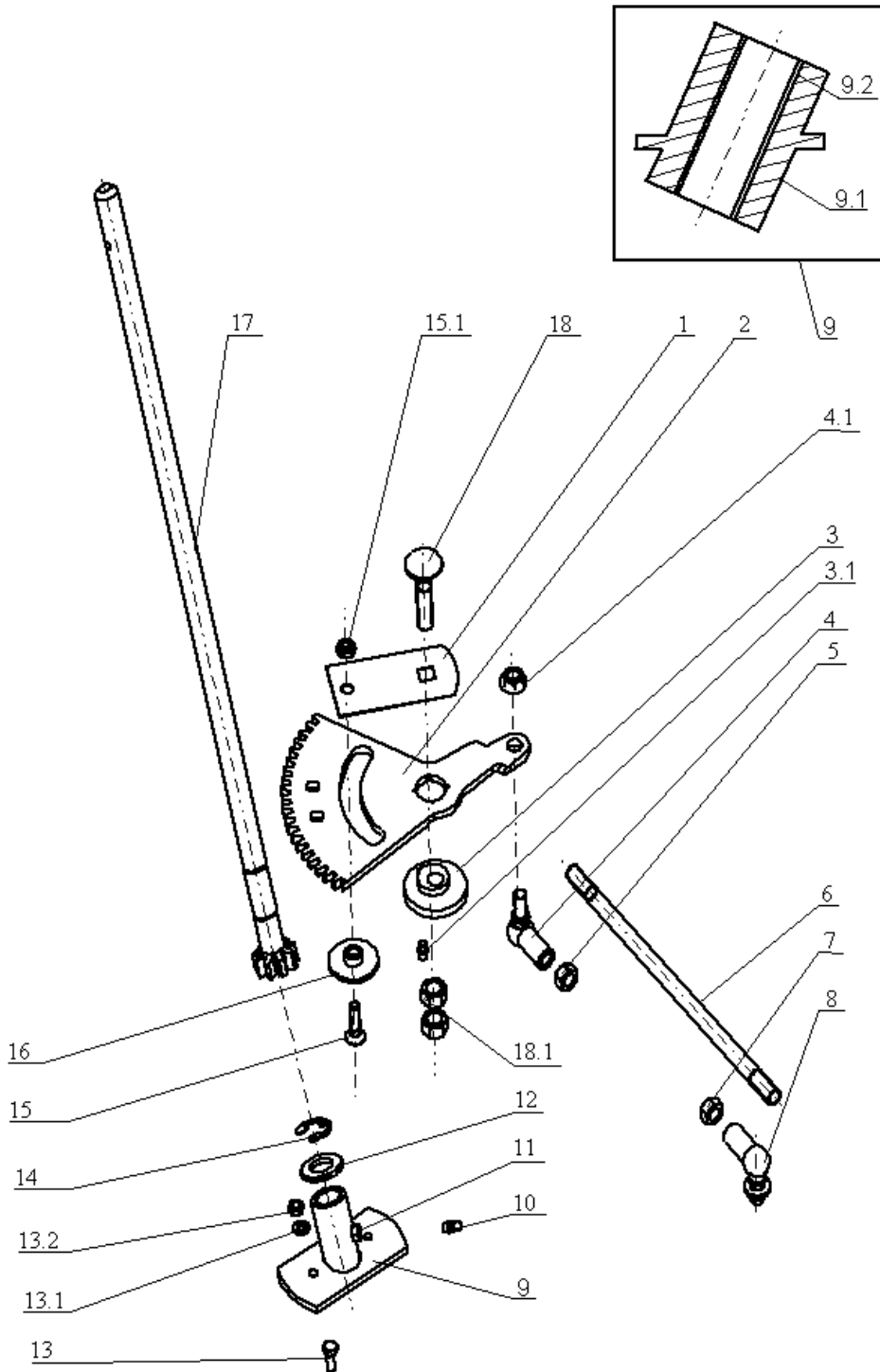

Illustration Lenkgetriebe

Bild Nr.	St.- Zahl	Teile Nr.	Beschreibung
1	1	SG532113322803	Platte
2	1	SG532033322083	Zahnrad
3	1	SG532080272033	Exzenter
3.1	1	SG947425111004	Fettnippel
4	1	SG947442073019	Dichtung
4.1	2	SG947311129521	Mutter
5	1	SG947311120539	Mutter
6	1	SG947532980125	Spannstange
7	1	SG947311120504	Sechskantmutter
8	1	SG947442073020	Dichtung
9	1	SG532938703443	Halter
9.1	1	SG532938542063	Halter
9.2	2	SG947323721002	Buchse
10	1	SG947425111004	Fettnippel
11	1	SG947311210530	Scheibe
12	1	SG947311210514	Scheibe
13	2	SG947309503557	Sechskantschraube
13.1	2	SG947311212516	Scheibe
13.2	2	SG947311129513	Sichermutter
14	1	SG947311732008	Kobelring
15	1	SG947309578506	Schraube
15.1	1	SG947311120520	Mutter
16	1	SG947532150538	Distanzstück
17	1	SG532930252103	Zahnrad
18	1	SG947309019522	Schraube
18.1	2	SG947311120504	Sechskantmutter

Illustration Mäheraushebung-schaltung

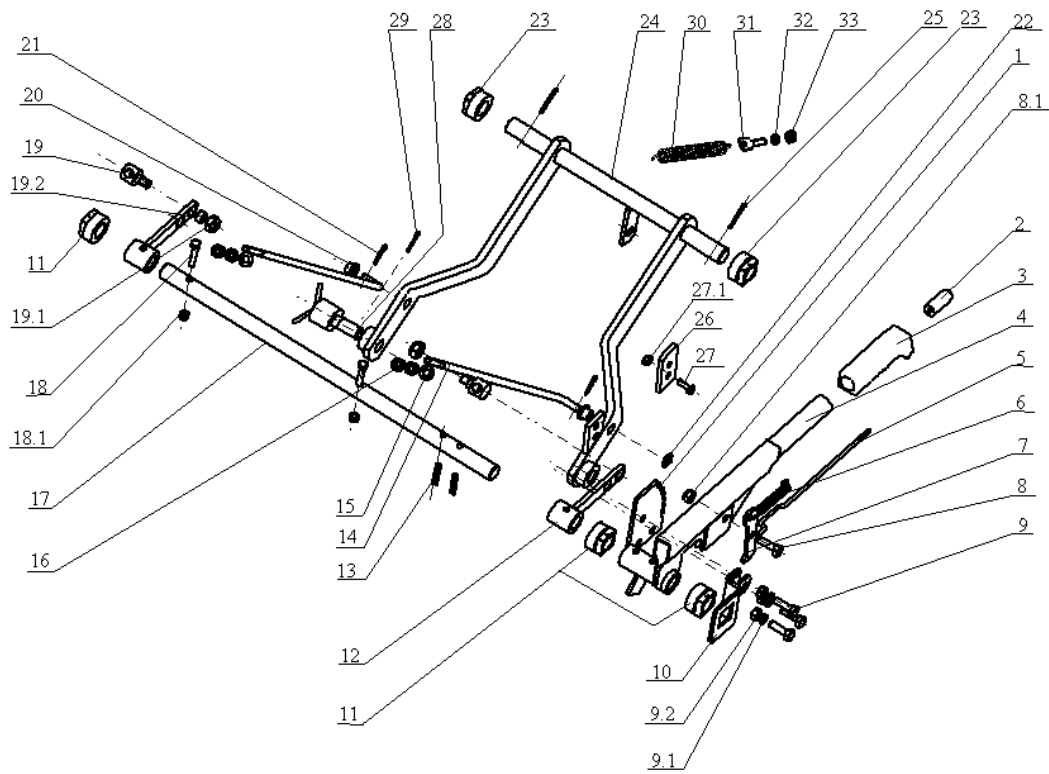

Illustration Mäheraushebung-schaltung

Bild Nr.	St.- Zahl	Teile Nr.	Beschreibung
1	1	SG532037322183	Zahnrad
2	1	SG947722643016	Schalter
3	1	SG947532150049	Handgriff
4	1	SG532980522163	Hebel
5	1	SG947315238034	Pleuel
6	1	SG947315231158	Feder
7	1	SG947532150641	Klinke
8	1	SG947309203517	Sechskantschraube
8.1	1	SG947311129501	Sichermutter
9	3	SG947309503512	Schraube
9.1	3	SG947311214502	Scheibe
9.2	3	SG947311120502	Mutter
10	1	SG532113414183	Halter
11	3	SG947722643022	Buchse
12	2	SG532980462853	Arm
13	2	SG947315238041	Feder
14	2	SG532080402683	Hebel
15	2	SG947311210503	Scheibe
16	4	SG947311120502	Mutter
17	1	SG532038102853	Welle
18	2	SG947309501568	Schraube
18.1	2	SG947311129513	Sichermutter
19	2	SG947532150507	Schraube
19.1	2	SG947311129502	Mutter
19.2	2	SG532195203273	Distanzstück
20	2	SG947532150537	Ring
21	2	SG947311338516	Splint
22	2	SG947311210503	Scheibe
23	2	SG947722643022	Buchse
24	1	SG532980508103	Hebel
25	2	SG947311338517	Splint
26	1	SG532114327223	Kupplungsblock
27	2	SG947309578522	Schraube
27.1	2	SG947311129501	Sichermutter
28	2	SG532993462153	Stift
29	2	SG947315238003	Ring
30	1	SG947315231165	Feder
31	1	SG947309599018	Schraube
32	1	SG947311214503	Scheibe
33	1	SG947311120503	Sechskantmutter

Illustration Motor

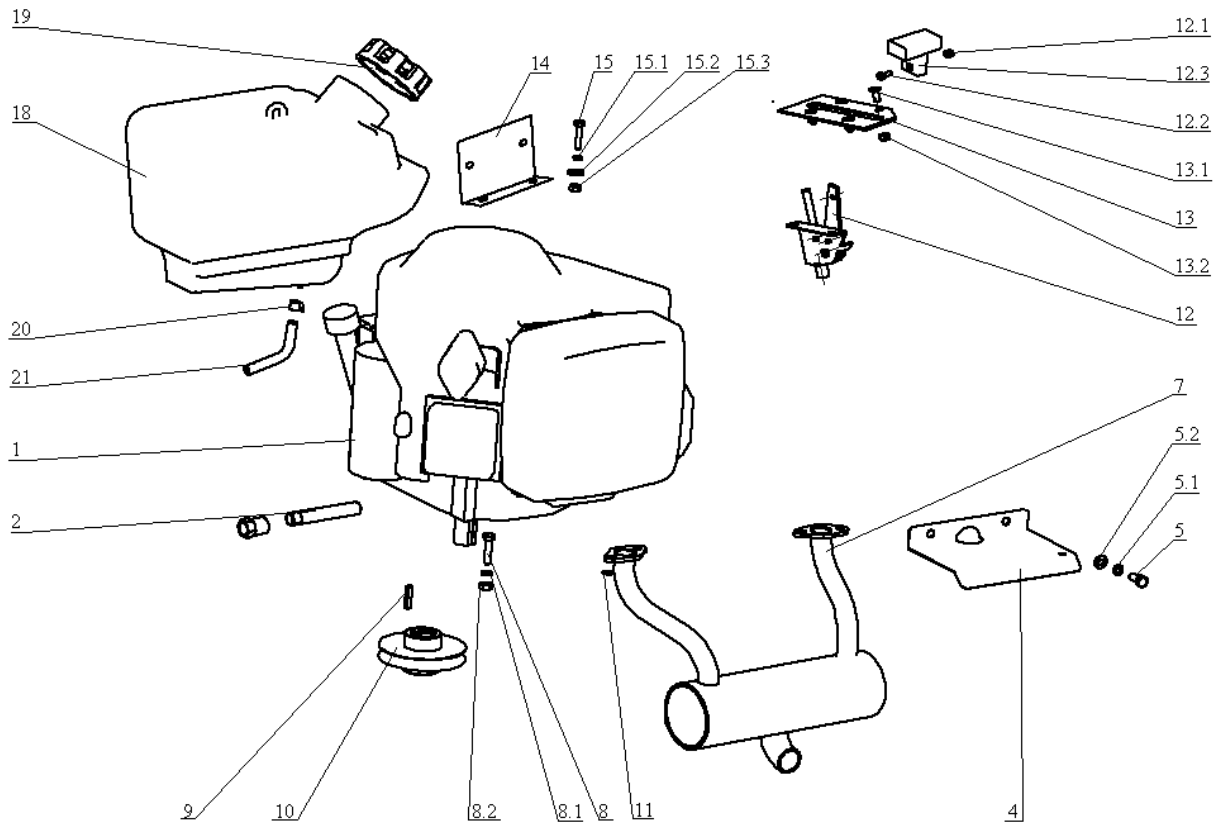

Illustration Motor

Bild Nr.	St.- Zahl	Teile Nr.	Beschreibung
2	1	SG532927262043	Verlaengerung
4	1	SG532085415543	Deckel
5	2	SG947309203504	Schraube
5.1	2	SG947311214502	Scheibe
5.2	2	SG947311210503	Scheibe
7	1	SG532927472403	Auspufftopt
8	4	SG947309203564	Sechskantschraube
8.1	4	SG947311214502	Scheibe
8.2	4	SG947311120502	Mutter
9	1	SG532092312153	Schlüssel
10	1	SG947532150439	Scheibe
11	4	SG947311214502	Scheibe
12	1	SG947443900115	Gashebel
12.1	1	SG947311129514	Mutter
12.2	1	SG947309231505	Schraube
12.3	1	SG947443900093	Gashebel
13	1	SG532115308583	Halter
13.1	4	SG947309251514	Schraube
13.2	4	SG947311129515	Sichermutter
14	1	SG532113403813	Halter
15	2	SG947309203502	Sechskantschraube
15.1	2	SG947311210502	Scheibe
15.2	2	SG947311214501	Scheibe
15.3	2	SG947311120501	Sichermutter
18	1	SG532027662043	Tank
19	1	SG947321841017	Stopfen
20	2	SG947000532058	Klammer
21	1	SG532199202323	Schlauch

Illustration Schneidwerkzeug (1/2)

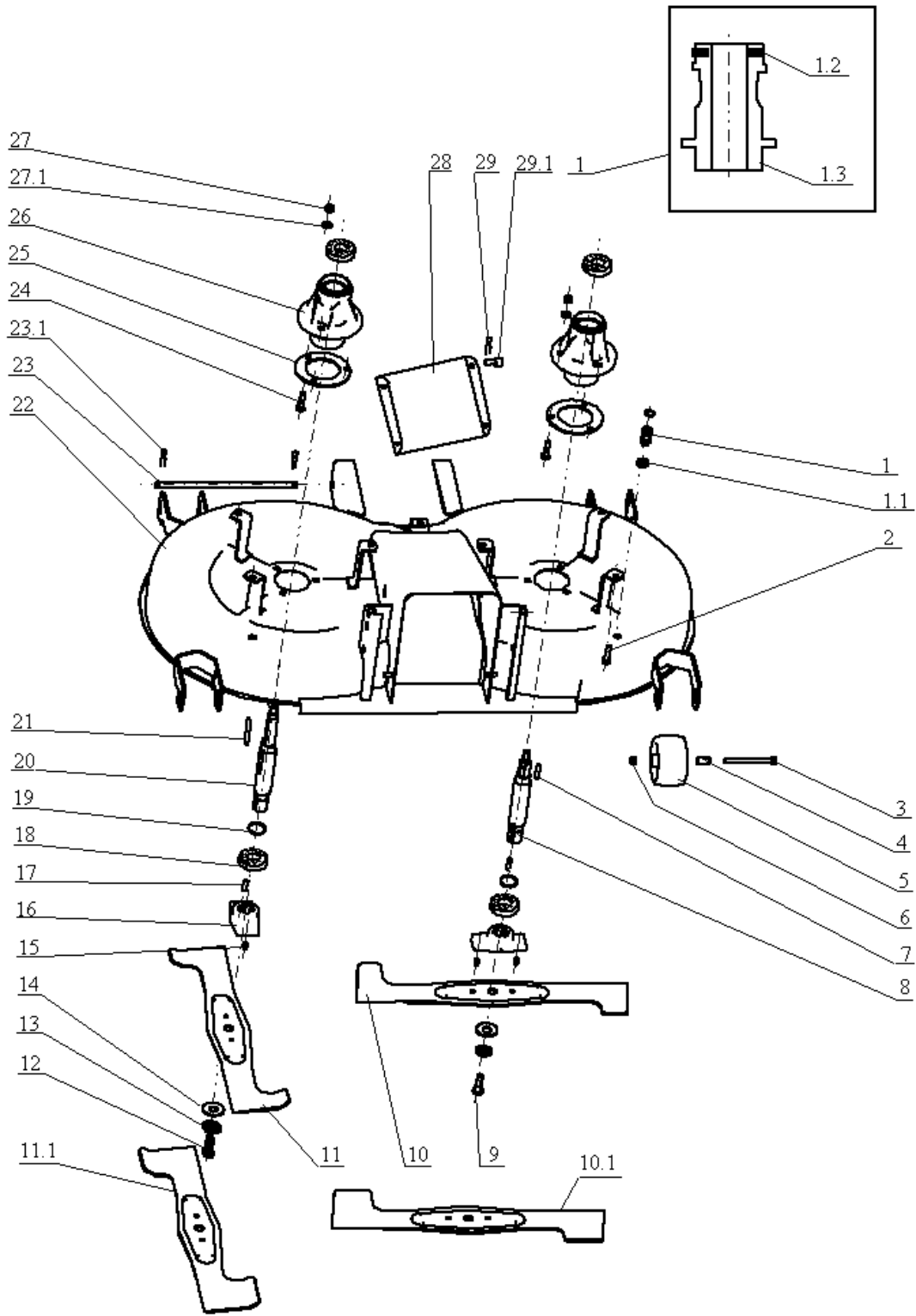

Illustration Schneidwerkzeug (1/2)

Bild Nr.	St.- Zahl	Teile Nr.	Beschreibung
1	2	SG532990362343	Kupplung
1.1	2	SG947311120511	Sechskantmutter
1.2	2	SG947273111054	Ring
1.3	2	SG947532150533	Kupplung
2	6	SG947309503518	Schraube
3	4	SG947309201524	Sechskantschraube
4	4	SG947532150539	Distanzstück
5	4	SG947532940114	Walze
6	4	SG947311129501	Sichermutter
7	1	SG947311726009	Schlüssel
8	1	SG532038128023	Welle
9	1	SG947309599008	Schraube
10	1	SG532050422543	Blatt
10.1	1	SG532050422483	Blatt
11	1	SG532050422533	Blatt
11.1	1	SG532050422473	Blatt
12	1	SG947309599017	Sechskantschraube
13	2	SG947532150519	Scheibe
14	2	SG947311219503	Scheibe
15	4	SG947532980077	Stift
16	2	SG532098212403	Anpassungsglied
17	2	SG947311726014	Schlüssel
18	4	SG947324162099	Lager
19	2	SG947311733014	Kobelring
20	1	SG532038128033	Welle
21	1	SG947311726019	Schlüssel
22	1	SG532950472083	Deck
23	1	SG532193102893	Stift
23.1	2	SG947315238035	Stift
24	6	SG947309503543	Sechskantschraube
25	2	SG532098203373	Dichtung
26	2	SG532038523833	Deckel
27	6	SG947311129501	Sichermutter
27.1	6	SG947311210503	Scheibe
28	1	SG532080503503	Einstellen
29	2	SG947315238003	Ring
29.1	2	SG947311613002	Stift

Illustration Schneidwerkzeug (2/2)

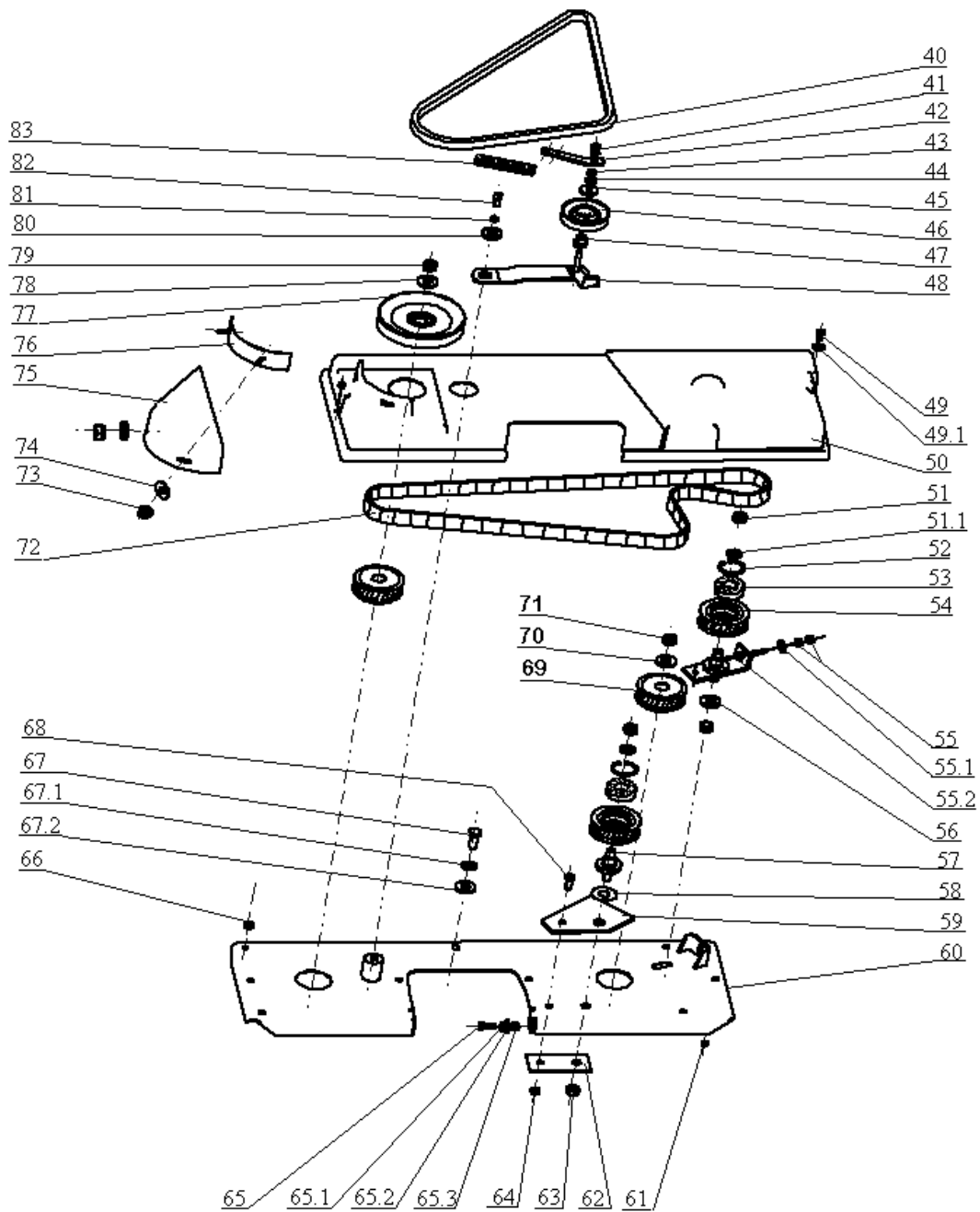

Illustration Schneidwerkzeug (2/2)

Bild Nr.	St.- Zahl	Teile Nr.	Beschreibung
40	1	SG947272731192	Riemen 17x1400
41	2	SG947311120520	Mutter
42	1	SG532113402353	Hebel
43	1	SG947311120502	Mutter
44	1	SG947311214502	Scheibe
45	1	SG947311212508	Scheibe
46	1	SG947000532002	Scheibe
47	1	SG947532150517	Stift
48	1	SG532913422403	Hebel
49	2	SG947309503557	Sechskantschraube
49.1	4	SG947311212516	Scheibe
50	1	SG947532150210	Riemendeckel
51	2	SG947311129505	Sichermutter
51.1	2	SG947311210505	Scheibe
52	2	SG947311733079	Ring
53	2	SG947324162098	Lager
54	2	SG532933712743	Scheibe
55	2	SG947311120502	Mutter
55.1	1	SG947311212517	Scheibe
55.2	1	SG532914412313	Mutter
56	1	SG532092207533	Scheibe
57	1	SG532993122683	Stift
58	1	SG532092207703	Scheibe
59	1	SG532096303973	Halter
60	1	SG532985423313	Platte
61	2	SG947311129513	Sichermutter
62	1	SG532092303963	Halter
63	2	SG947311129505	Sichermutter
64	1	SG947311129501	Sichermutter
65	2	SG947309019501	Schraube
65.1	2	SG947311210505	Scheibe
65.2	2	SG947311210503	Scheibe
65.3	2	SG947311129501	Sichermutter
66	6	SG947311129501	Sichermutter
67	1	SG947309503518	Schraube
67.1	1	SG947311214502	Scheibe
67.2	1	SG947311210503	Scheibe
68	1	SG947309203517	Sechskantschraube
69	2	SG532933712773	Scheibe
70	1	SG947532150645	Scheibe
71	1	SG947311129505	Sichermutter
72	1	SG947272211006	Riemen
73	2	SG947311129513	Sichermutter
74	2	SG947311212516	Scheibe
75	1	SG947532150559	Deckel
76	1	SG532985402733	Dichtung

Illustration Schneidwerkzeug (2/2)

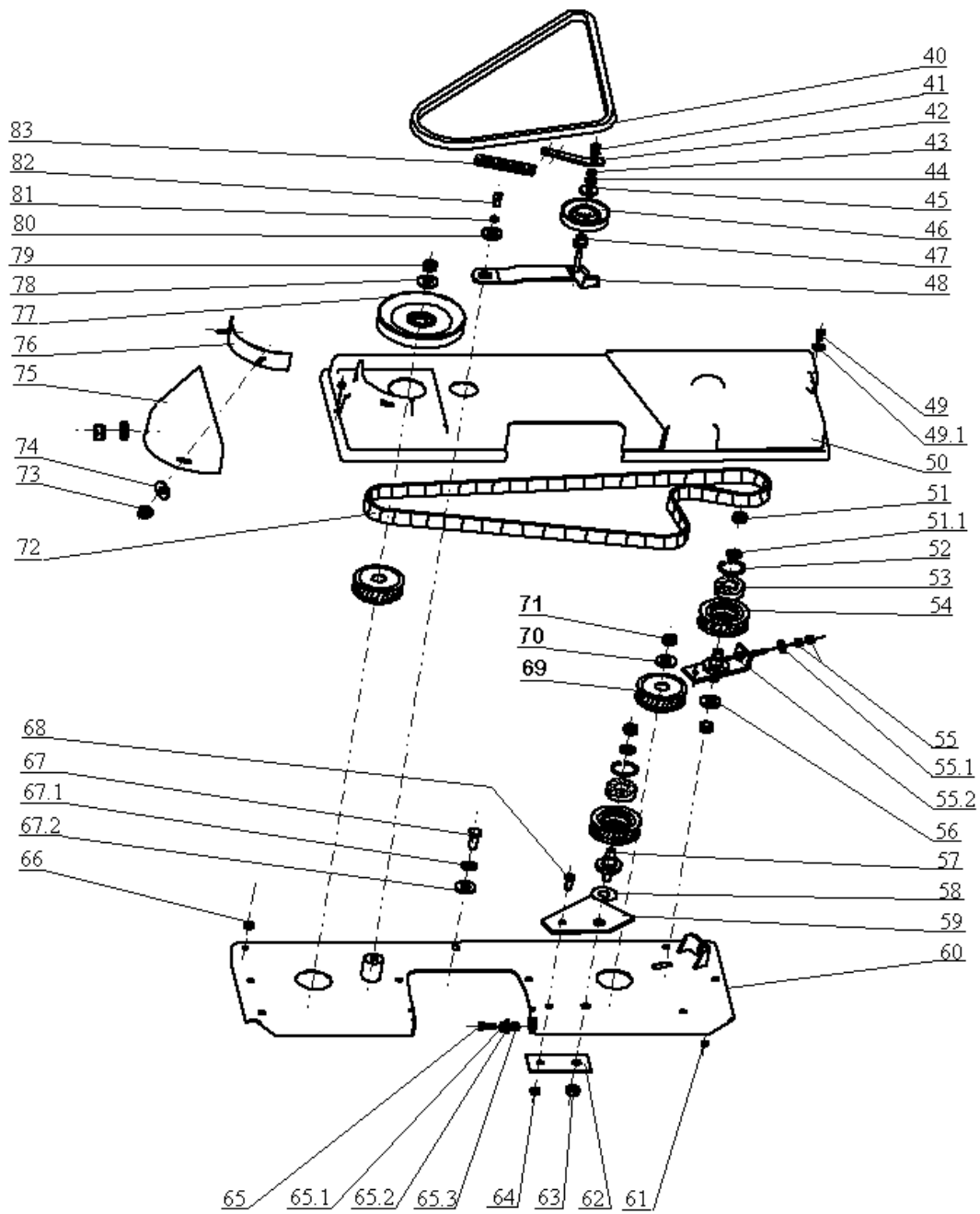

Illustration Schneidwerkzeug (2/2)

Bild Nr.	St.- Zahl	Teile Nr.	Beschreibung
77	1	SG947532150164	Scheibe
78	1	SG532092207273	Scheibe
79	1	SG947311129505	Sichermutter
80	1	SG947532150520	Scheibe
81	1	SG947311214502	Scheibe
82	1	SG947309543506	Sechskantschraube
83	1	SG947315231193	Feder

Illustration Vorderachse

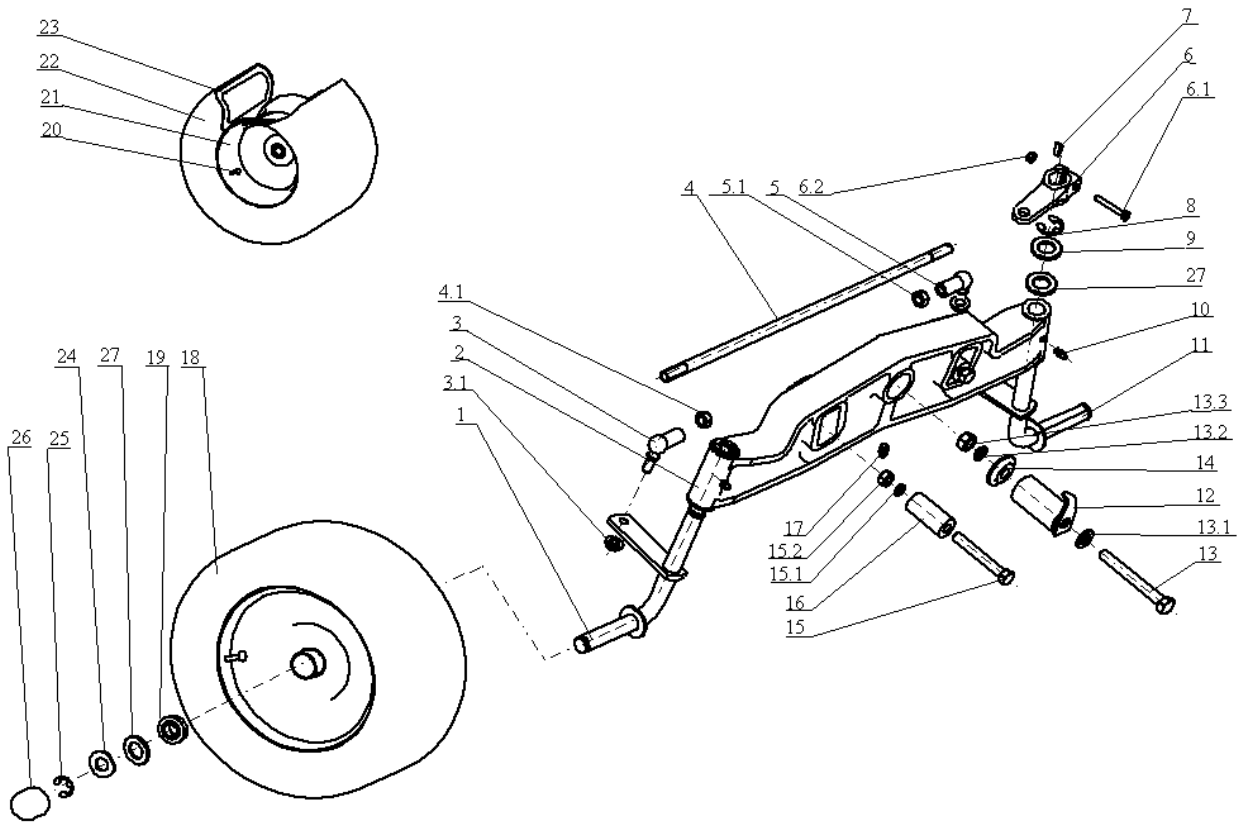

Illustration Vorderachse

Bild Nr.	St.- Zahl	Teile Nr.	Beschreibung
1	1	SG532916432153	Stift
2	1	SG532016542063	Vorn achse
3	1	SG947442073020	Dichtung
3.1	2	SG947311129521	Mutter
4	1	SG947532980126	Spannstange
4.1	1	SG947311120504	Sechskantmutter
5	1	SG947442073019	Dichtung
5.1	1	SG947311120539	Mutter
6	1	SG532080503603	Hebel
6.1	1	SG947309203524	Sechskantschraube
6.2	1	SG947311129513	Sichermutter
7	1	SG947311728003	Schlüssel
8	2	SG947311732008	Kobelring
9	4	SG947311210514	Scheibe
10	2	SG947425111004	Fettnippel
11	1	SG532016432143	Stift
12	1	SG532993164373	Stift
13	1	SG947309501534	Sechskantschraube
13.1	1	SG947311210505	Scheibe
13.2	1	SG947311214504	Scheibe
13.3	1	SG947311120504	Sechskantmutter
14	1	SG947532150518	Scheibe
15	2	SG947309201540	Sechskantschraube
15.1	2	SG947311214503	Scheibe
15.2	2	SG947311120503	Sechskantmutter
16	2	SG947532150543	Buchse
17	1	SG947425111016	Fettnippel
18	2	SG947532940113	Rad
19	4	SG947324196015	Halter
20	2	SG947000532135	Ventil
21	2	SG947000532124	Rad
22	2	SG947000532123	Reifen
23	2	SG947000532125	Reifenschlauch
24	2	SG532092207393	Scheibe
25	2	SG947311732008	Kobelring
26	2	SG947532150208	Deckel
27	8	SG532092208153	Scheibe